

DRI OCT Triton2

Swept-Source Optical Coherence Tomography
True Colour Fundus Camera

Next-Generation Multimodal Swept-Source OCT



NEXT-GENERATION MULTIMODAL SWEPT-SOURCE OCT

Enhance clinical efficiency without compromise.

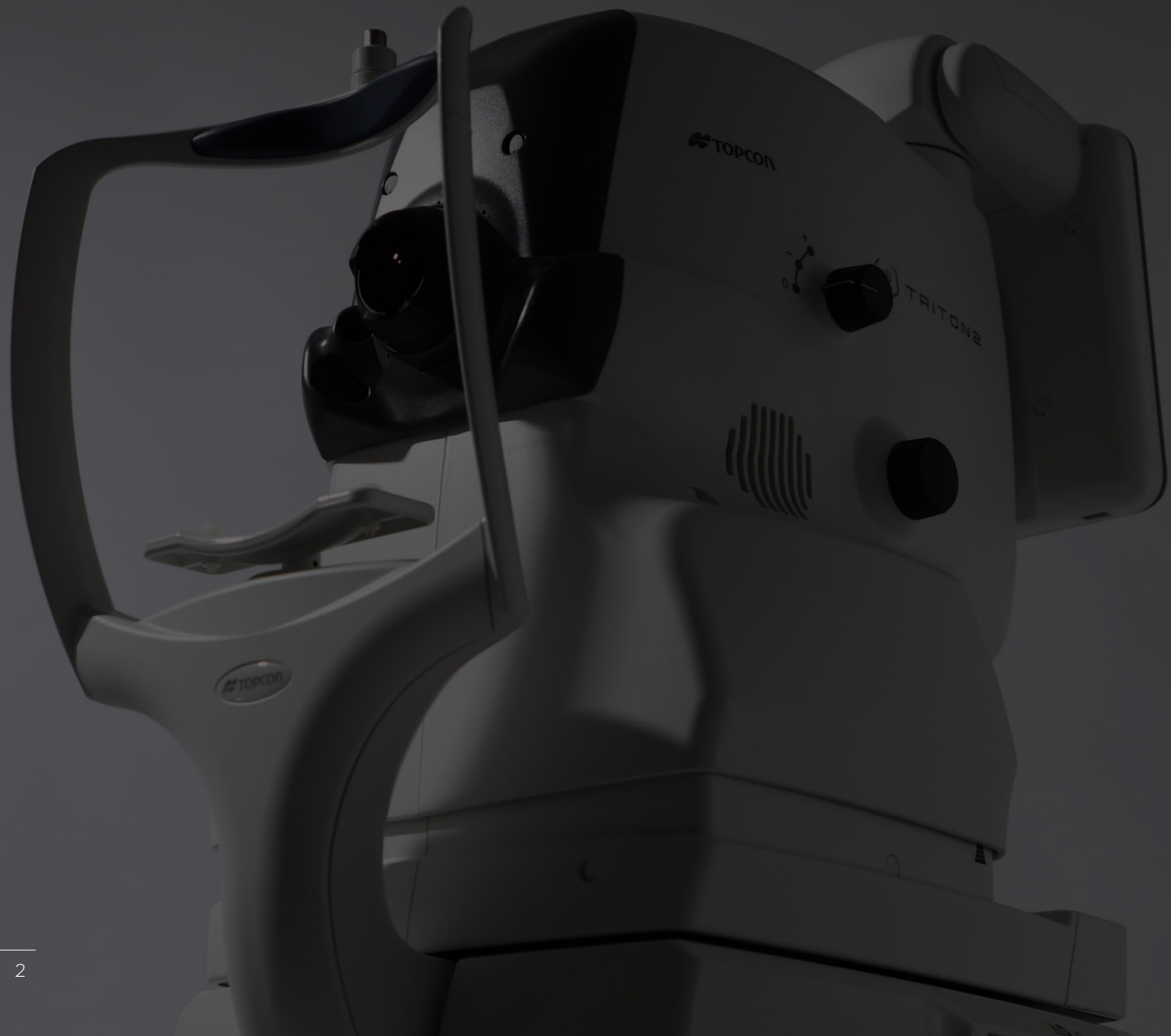

KEY FEATURES | TRITON2

- ✓ Swept-Source OCT providing high density scans and **deep penetration**
- ✓ Slit-scan technology to image through **small pupils ($\phi 2.0\text{mm}$ or larger^{*1})**
- ✓ Wide-field OCT and OCTA, **up to 21mm^{*2}**
- ✓ Smart Denoise^{*2} provides **higher signal-to-noise ratio** on 3D OCT and OCTA^{*2}
- ✓ **Flexible positioning** for easier acquisition
- ✓ **Simplified workflow** with seamless integration for quick analysis and follow-up

Invisible Scan Lines

The invisible 1,050nm wavelength light helps patients concentrate on the fixation target during the scan, reducing involuntary eye movement. It supports more efficient workflow in practice by reducing the need to rescan.

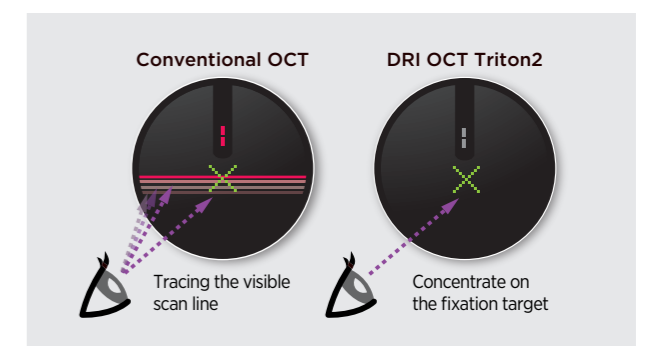

Swept-Source OCT Technology

A fast scanning speed of 100,000 A-scans/sec enables capture of a dense array of clear B-scans by acquiring more A-scans within a given image acquisition time.

This helps to reduce artifacts from involuntary eye movements such as saccades and blinks.

^{*1} Confirmed with model eye
^{*2} Optional

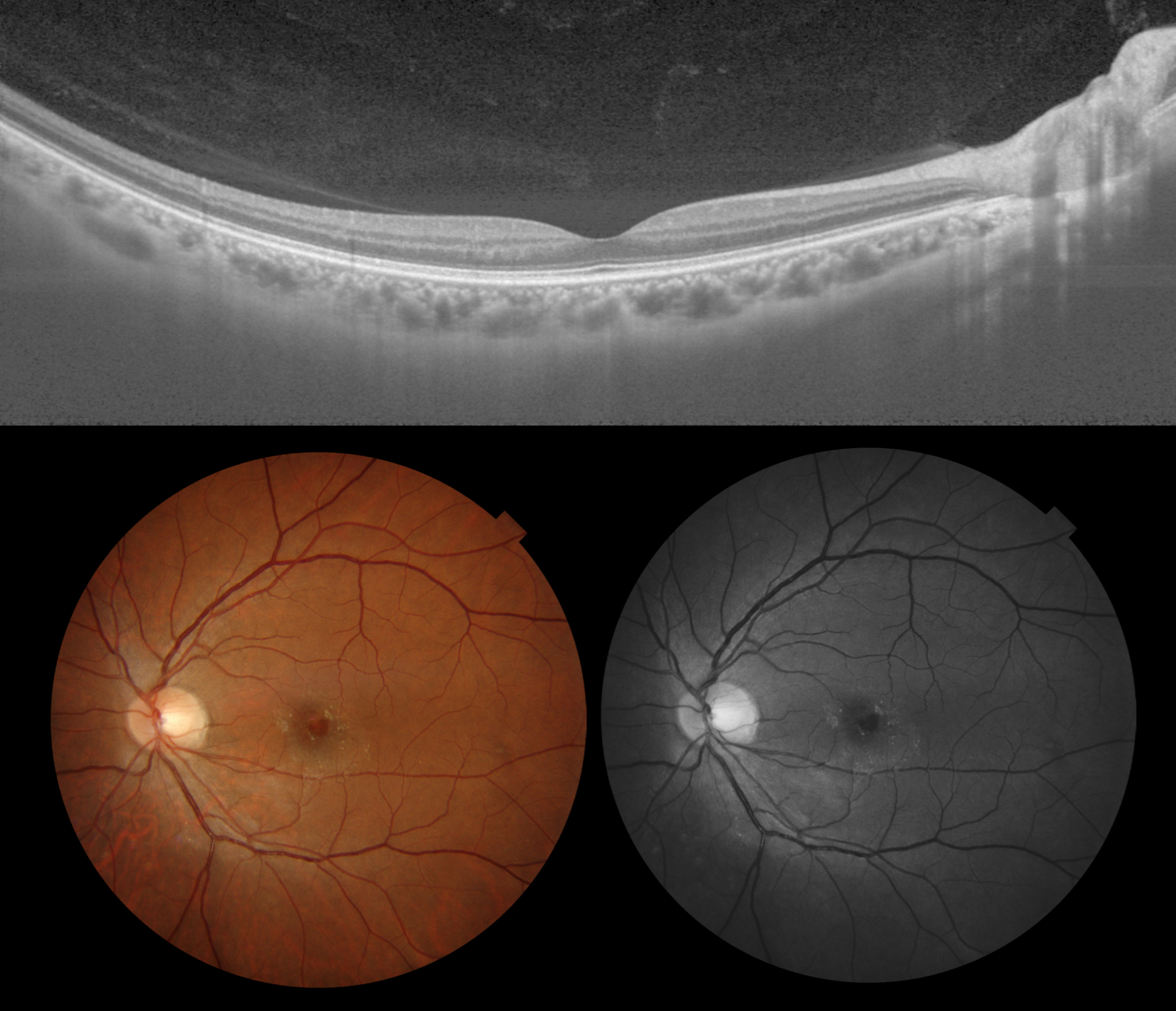

Combination Scan

The Triton2 allows for the combination of a 3D volumetric scan with reference database, and a high-resolution linear scan in a single acquisition.

Introducing New Slit-Scan Photography

The innovative slit-scan illumination and rolling shutter mechanism in the Triton2 produces excellent quality colour fundus images with less flare and shadow.*3

The slit-scan mechanism helps to overcome one of the known causes of poorly graded images, with its ability to effectively image through small pupils.

This innovative technology also helps the Triton2 capture sharp, high-quality fundus images, regardless of miosis and the lighting conditions, unlike conventional fundus cameras.

Retina	ILM-OS/RPE
RNFL	ILM-RNFL/GCL
GCL++	ILM-IPL/INL
GCL+	RNFL/GCL-IPL/INL
CSI	BM-CSI

Retinal and Choroidal Thickness Maps

IMAGEnet7 provides up to 5 retinal thickness maps, enabling quantification of retinal layers and sub-layers. The Triton2 provides clear visualisation of the choroid and generates choroidal thickness maps, supporting clinicians in gaining a clearer understanding of choroidal structural changes.

*3 As compared to Topcon conventional non-mydratric retinal camera TRC-NW400

Wide-field Imaging

The optional wide-field attachment lens enables the capture of scans up to 21mm in length. Gather more clinical insights with wide-field OCT and OCTA imaging - valuable in a wide variety of conditions.

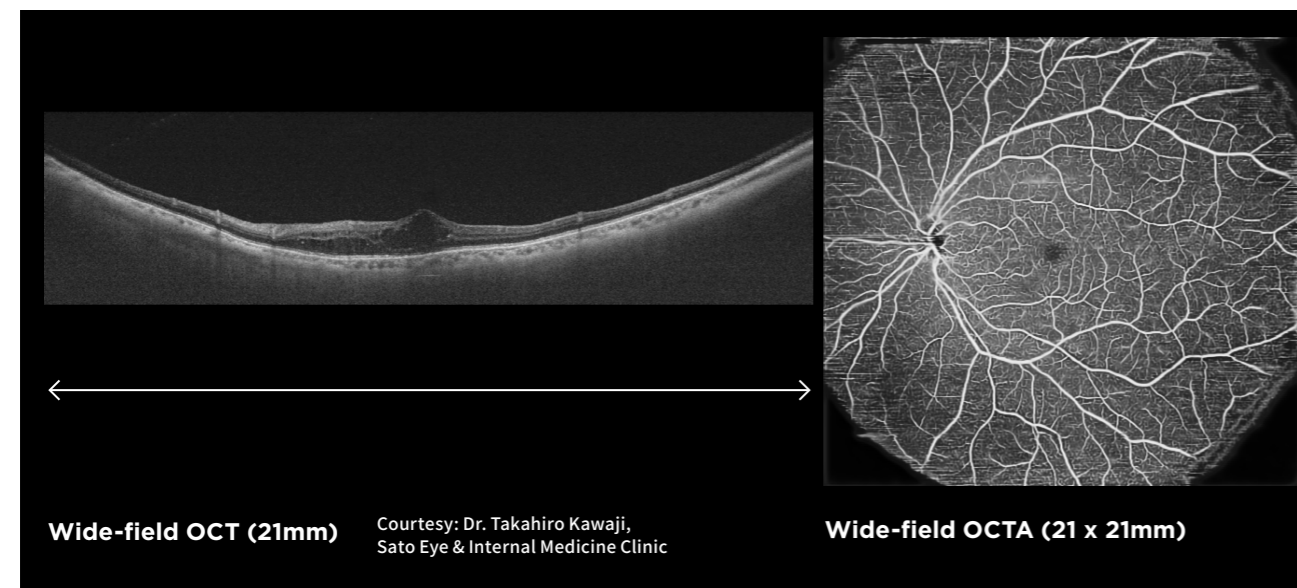

Mosaic Image



Angle of view

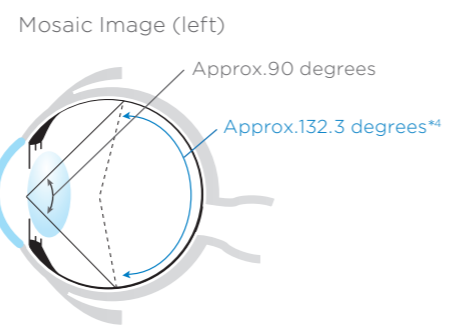
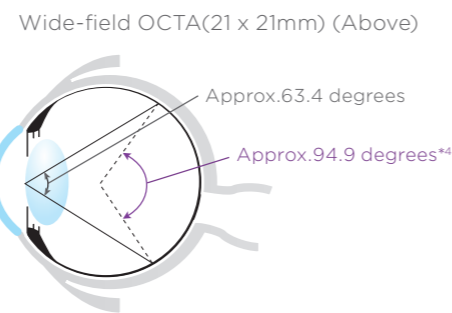

Topcon's optional SS OCT Angiography

Topcon's option SS OCT Angio™ integrates OCT Angiography with Swept-Source technology, and the long 1050 nm wavelength. Powered by OCTARA™, a proprietary image processing algorithm, SS OCT Angiography enables detailed visualisation of vascular structures and the monitoring of key retinal pathologies.

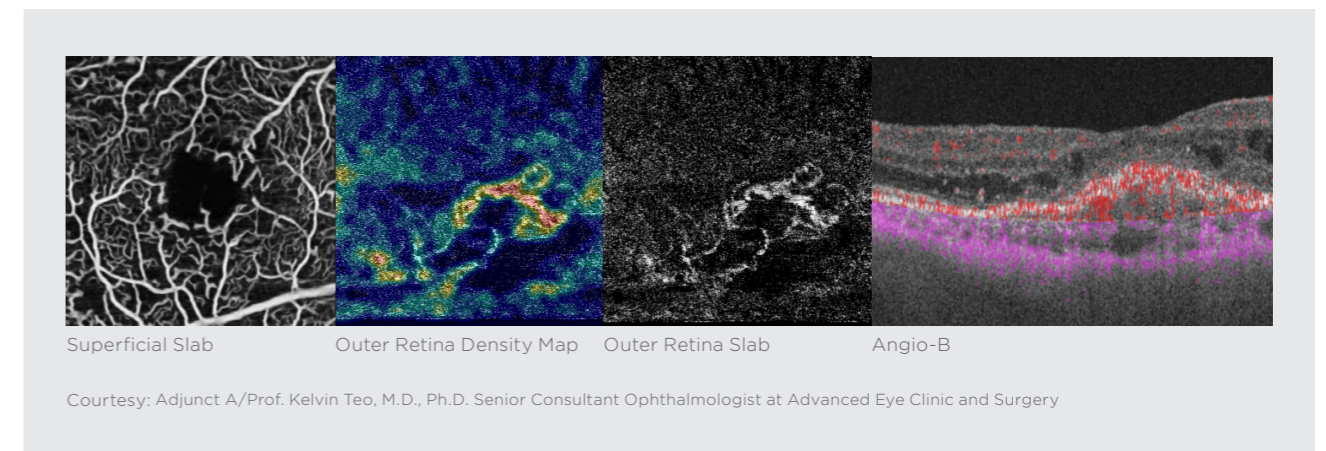

OCTA Metrics

SS OCT Angio™ displays OCTA density which is the ratio between high and low signal areas. The information is displayed as a colour map with the ability to display values for rapid comprehension.

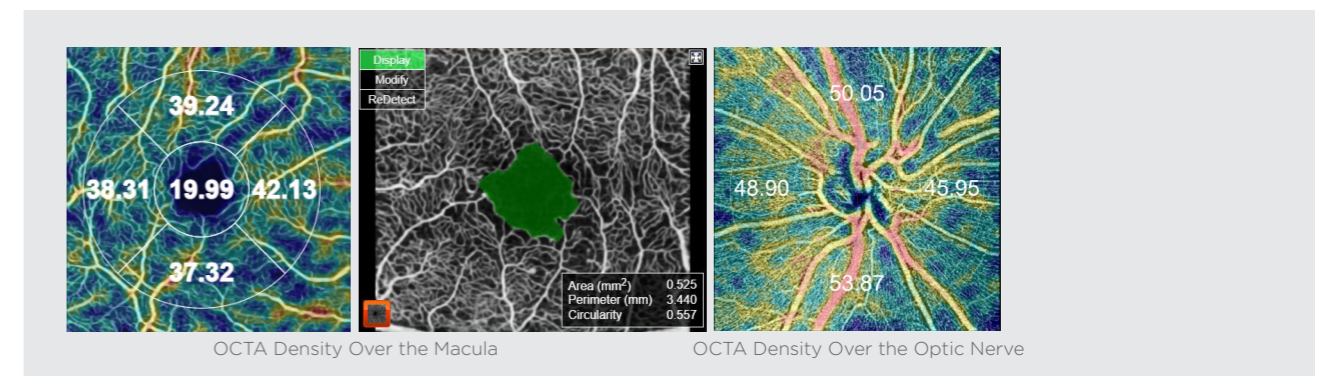

En Face OCT Imaging

En Face imaging allows for independent dissection and examination of key layers, such as the vitreoretinal interface (ILM boundary), retinal pigment epithelium and choroidal layers.

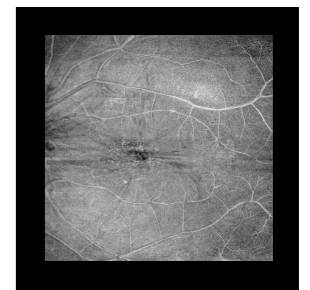

*This is a reference image captured with the DRI OCT Triton. Courtesy : Aravind Eye Hospitals, India

^{*4} Xincheng Yao, Devrim Toslak, Taeyoon Son, Jiechao Ma. Understanding the relationship between visual-angle and eye-angle for reliable determination of the field-of-view in ultra-wide-field fundus photography. Biomedical Optics Express, 2021 Sep 30;12(10):6651-6659

Volumic OCT scan

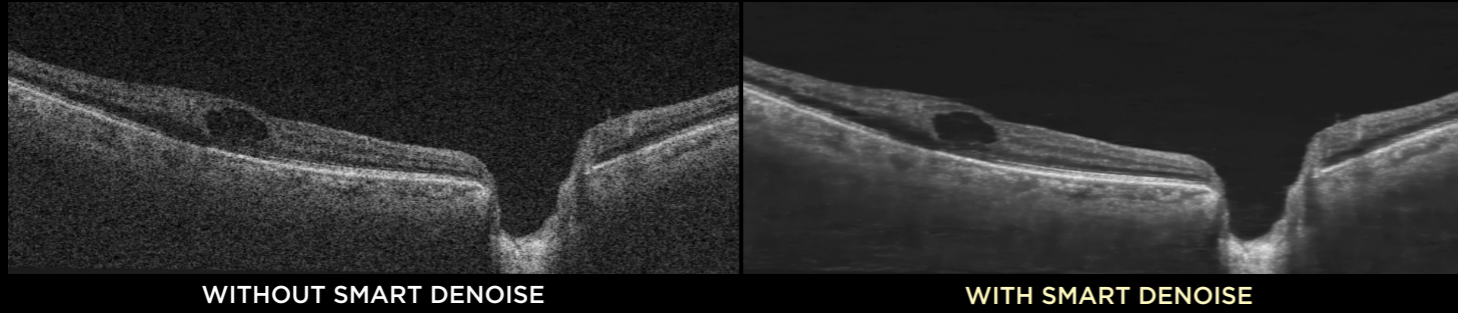

OCT-Angiography

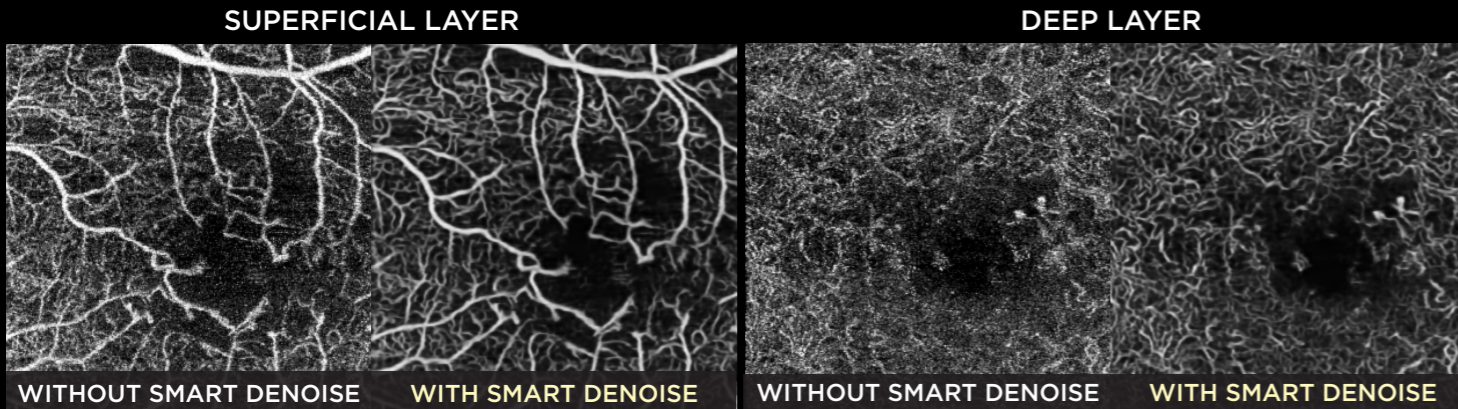

Image is one of the 256 B-scans captured as part of Triton2's 12x9mm 3D Wide Scan.



DIAGNOSTIC CAPABILITIES

Smart Denoise*⁵

Smart Denoise is an image processing algorithm which reduces artifacts and increases contrast. High quality OCT and OCTA images with reduced noise signal are generated from every B-scan within the dense data cubes, through the use of Topcon's unique AI algorithm.

Intuitive Scan Placement with Fundus-Guided Acquisition (FGA)

Easily define OCT scan locations by selecting the area of interest directly on the fundus image. With FGA, operators can capture or import a fundus image, pinpoint the desired location, and automatically acquire a single B-scan or a series of B-scans.



Follow-Up Function

The follow-up function enables easy retrieval and re-analysis of the same location, allowing seamless comparison of past and current data. Operators simply select previous scan data, and Triton2 automatically captures the corresponding area.

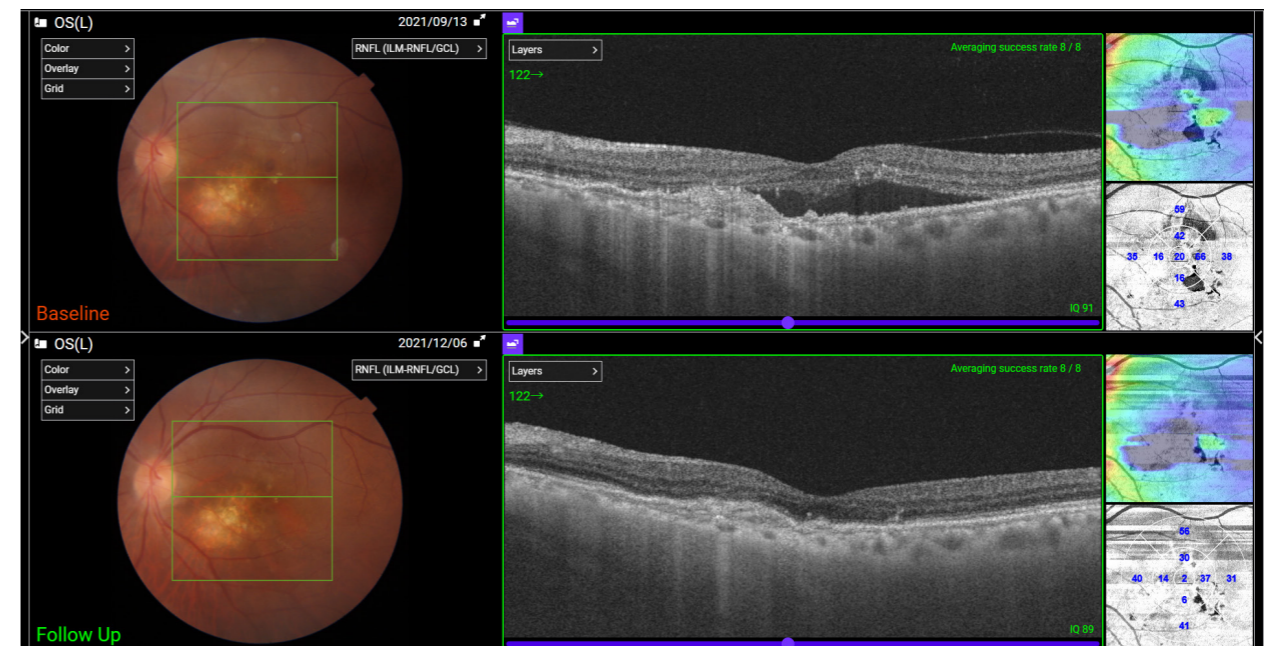

3D Wide Scan for Complete Posterior Pole Assessment

The 12x9mm 3D Wide scan captures both the optic nerve and macula in a single acquisition, delivering a thorough evaluation of the posterior pole. The Triton2 reference database extends across the entire scan area, enabling detailed thickness comparisons within the visual field, ideal for detecting patterns such as thinning of the RNFL commonly seen in glaucoma*6.



Evaluation of Key Metrics Trends

IMAGEet7 offers intuitive timeline views and insightful graphs for a wide range of clinical data (RNFL, GCL, and more). The Trend View provides a powerful overview of changes over time at a glance, supporting informed and timely clinical decisions.

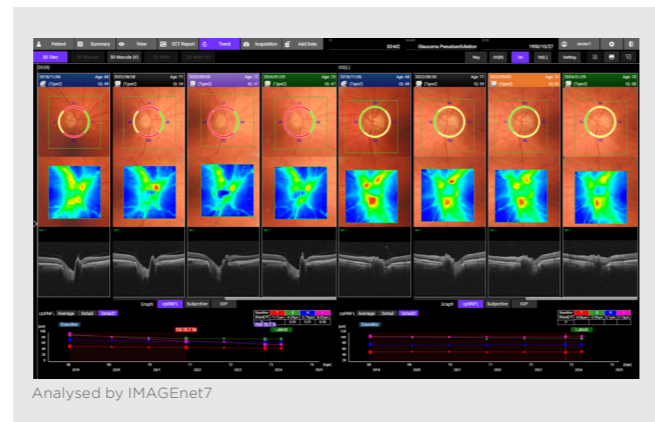

The Hood Report for Glaucoma

The Hood Report streamlines the decision-making process through the correlation of structure (GCL/RNFL) with function (overlay of visual field test locations)*7. A single wide-field OCT scan with Hood report can provide compelling information for the diagnosis of early glaucoma*8.

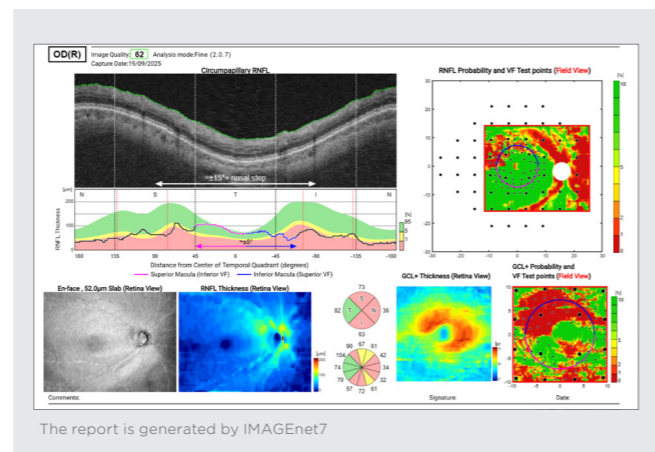

Anterior Segment Imaging

The optional anterior segment imaging capabilities allow for visualisation of the cornea, anterior chamber angle, iris and anterior sclera. The anterior segment lens attachment is combined with quantitative analysis. With the addition of the optional anterior segment features, Triton2 provides a valuable solution for comprehensive (anterior and posterior) eye care settings.



Comprehensive Assessment with Quantitative Analysis

Line scan length in 16mm

Delivering a 16mm wide scan, the Triton2 captures both iridocorneal angles in a single acquisition, enabling fast and efficient evaluation. Paired with IMAGEet7, it delivers angle measurements.

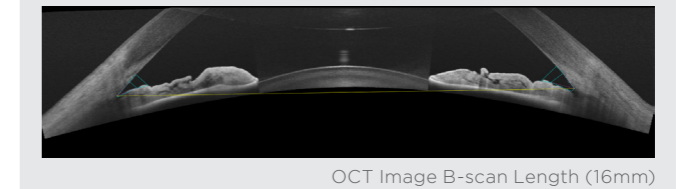

Radial scan length in 9mm

From the 9mm radial scan, the quantitative analysis provides automatic measurement of the total corneal, epithelial and stromal thickness, enabling the diagnosis and monitoring of various conditions.

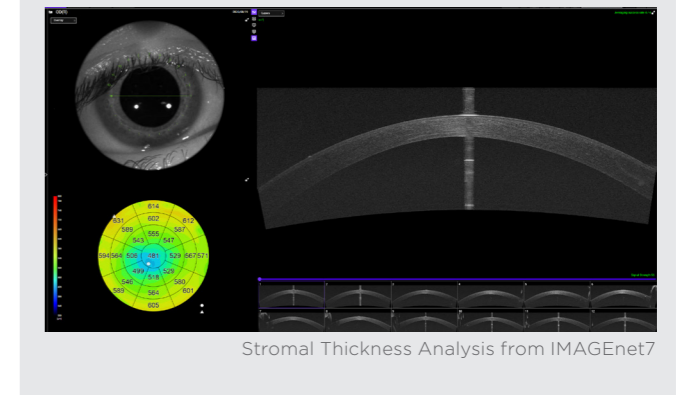

*6 Comparison of glaucoma-diagnostic ability between wide-field swept-source OCT retinal nerve fiber layer maps and spectral-domain OCT
 Won June Lee, Ki Ho Park et al, Eye volume 32, 2018
 Diagnostic Accuracy of Wide-Field Map from Swept-Source Optical Coherence Tomography for Primary Open-Angle Glaucoma in Myopic Eyes
 Yong Woo Kim, Jinho Lee, Jin-Soo Kim, Ki Ho Park. AJO, 2020
 *7 Donald C. Hood PhD, Translational Vision Science & Technology No.6 Vol.3 2014: Evaluation of a One-Page Report to Aid in Detecting Glaucomatous Damage.
 *8 A Single Wide-Field OCT Protocol Can Provide Compelling Information for the Diagnosis of Early Glaucoma
 Donald Hood et al, 2016 Translational Vision Science & Technology

OTHER FEATURES

SMARTTrack™

SMARTTrack™ enables the ability to capture an image of a designated location with automated tracking of the eye.

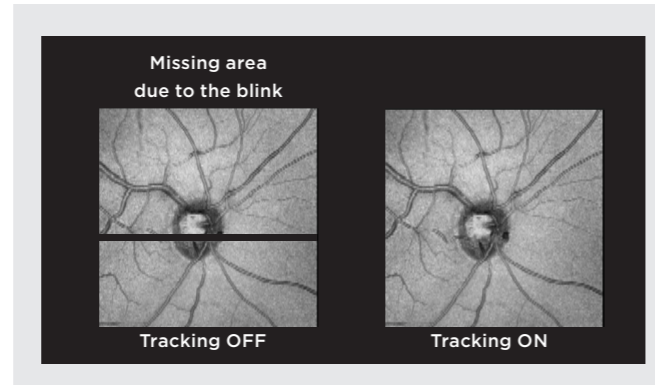

Projection Image

The projection image provides an easy means of confirming scan location when the OCT image capture is not accompanied by a colour fundus image. It's mostly used to check scan quality.

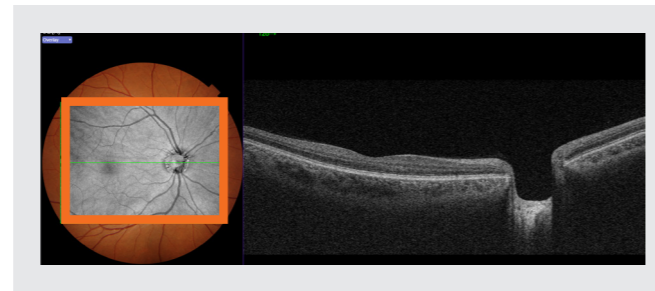

Alignment Navigation

Alignment navigation guides simplify operation of the device, directing the operator to achieve optimal positioning, reducing acquisition errors and supporting rapid capture.

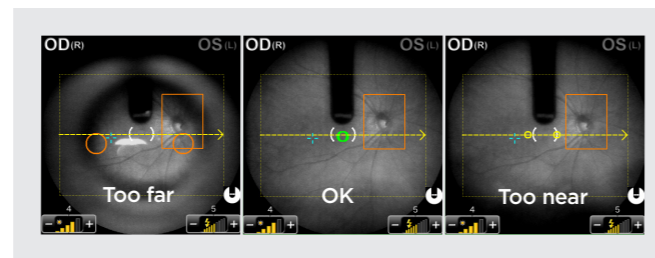

Live Fundus View

The fast scanning speed allows the Triton2 to create a live En Face fundus image, an ideal tool for precisely visualising the scan position. This enables the operator to be sure they are capturing the correct area, even in patients with small pupils.

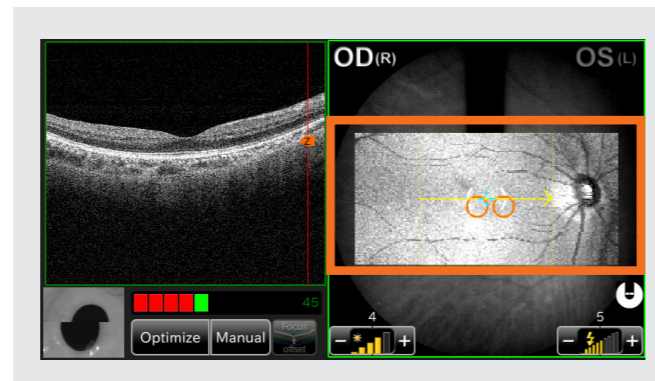

1

Triton2 Acquisition Control

In combination with IMAGEnet7, the operator can view the live image on a large desktop monitor during acquisition.

2

Flexible Rotating Control Panel

The flexible, 180° rotating control panel enables the operator to control the device from various positions, and support the patient easily if the eyelid needs to be lifted.

Trend Analysis Reports

Trend reports show the change in thickness measurements over time. The layers displayed (RNFL/GCL+/ GCL++) can be selected as required depending on the area scanned. Poor scans can be excluded and new baselines added when management changes.

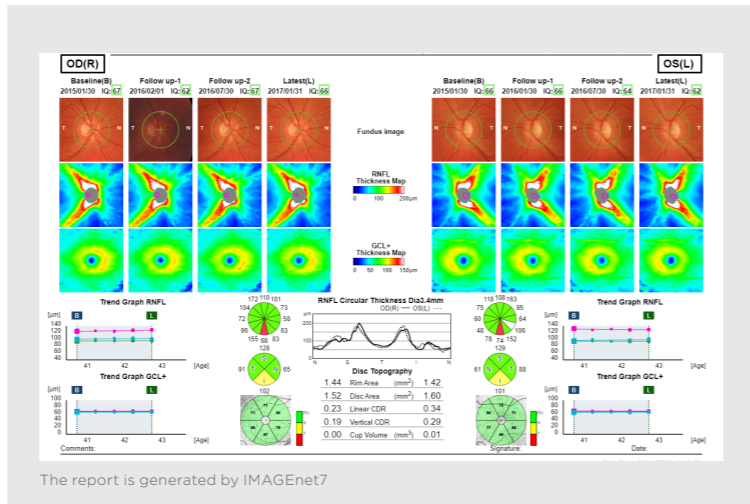

3D Wide Glaucoma Report

The 12x9mm Wide scan covers the optic nerve and macula and can be captured in one acquisition, to provide a comprehensive assessment of the posterior pole with reference database comparison.

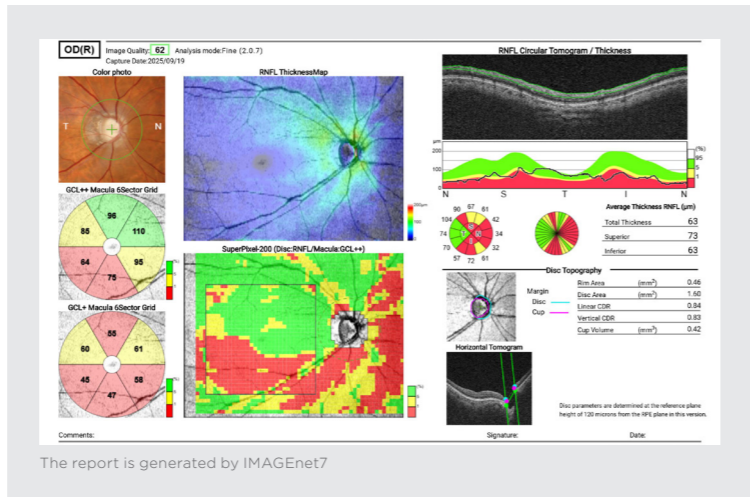

CONNECTIVITY

IMAGEnet7 is DICOM compliant, making it easy to integrate with PACS and EMR programs.

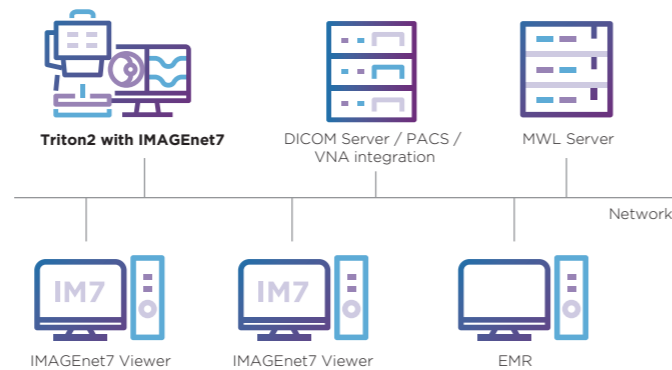

Observation and Photography of Fundus Image

Photography type	Colour Infrared light (IR)
Angular Field of View	50°±5%
Operating distance	35.5mm±0.1mm
Photographable diameter of pupil	φ2.0mm or more
Fundus image resolution [Optical resolution]	Colour Centre: 60 lines/mm or more Middle (r/2): 40 lines/mm or more Periphery (r): 25 lines/mm or more Infrared light (IR) Centre: 5 lines/mm or more * * Infrared (IR) photography is for adjusting the position of the area to be photographed, not for generating a fundus image. The resolution required for adjusting the position of the area to be photographed has been set as our own in-house standard.

Measurable range of dioptric power	-33D to +40D Without the dioptre compensation lens : -13D to +12D When the concave compensation lens is used *1: -33D to -12D When the convex compensation lens is used *1: +11D to +40D
------------------------------------	---

Observation and Capture of Fundus Tomographic Image

Scan range (on fundus)	Horizontal: 3 to 12mm ±5% Vertical: 3 to 12mm ±5%
Scan pattern	3D scan Linear scan (Line-scan/Cross-scan/Radial-scan)
Scan speed	100,000±5,000 A-Scans per second
Lateral resolution	20µm
In-depth resolution	Optical function: 8µm, Digital: 2.6µm±3%
Photographable diameter of pupil	φ2.5mm or more

Observation and Photography of Fundus Image / Observation and Capture of Fundus Tomographic Image

Fixation target	Internal fixation target : Dot matrix type organic EL display The display position can be changed and adjusted. The displaying method can be changed. Peripheral fixation target : This is displayed according to the internal fixation target displayed position. External fixation target
Measurable range of dioptric power for the patient's eye *2	Without the dioptre compensation lens : -13D to +12D When the concave compensation lens is used *1: -33D to -12D When the convex compensation lens is used *1: +11D to +40D

Observation and Photography of Anterior Segment Image *3

Photography type	Infrared light (IR)
Operating distance	17 ±0.3mm

Observation and Capture of Anterior Segment Tomographic Image *3

Operating distance	17 ±0.3mm
Scan range (on cornea)	Horizontal: 3 to 16mm ±5%, Vertical: 3 to 16mm ±5%
Scan pattern	3D scan Linear scan (Line-scan/Radial-scan)
Scan speed	100,000±5,000 A-Scans per second
Fixation target	External fixation target

Observation and Capture of Wide-field Fundus Tomographic Image *4

Scan range (on fundus)	Horizontal: 21mm ±10% (63.4°±8%) Vertical: 21mm ±10% (63.4°±8%)
Scan pattern	3D scan Linear scan (Line-scan/Cross-scan/Radial-scan)
Scan speed	100,000±5,000 A-Scans per second
Lateral resolution	30µm
In-depth resolution	8µm

Observation of Wide-field Fundus Image / Observation and Capture of Wide-field Fundus Tomographic Image *4

Measurable range of dioptric power for the patient's eye	Without the dioptre compensation lens : -7D to +40D When the concave compensation lens is used *1: -33D to -5D
--	---

Electric Rating	Dimensions and Weight
Source voltage	100-240V AC
Frequency	50-60Hz
Power input	130VA
	Dimensions 321-454mm (W) × 523-664mm (D) × 573-657mm (H)
	Weight 24.3kg±10%

*1 Split autofocus and manual focus with split lines cannot be used when using concave compensation lens or convex compensation lens.

*2 Fundus tomography observation and capturing only

*3 Observation and Photography of Anterior segment image and tomogram are available only when using ANTERIOR SEGMENT ATTACHMENT KIT AA-1.

*4 Observation and Photography of Wide-field fundus tomogram are available only when using Wide-field OCT attachment lens WA-1.

CASE IMAGES

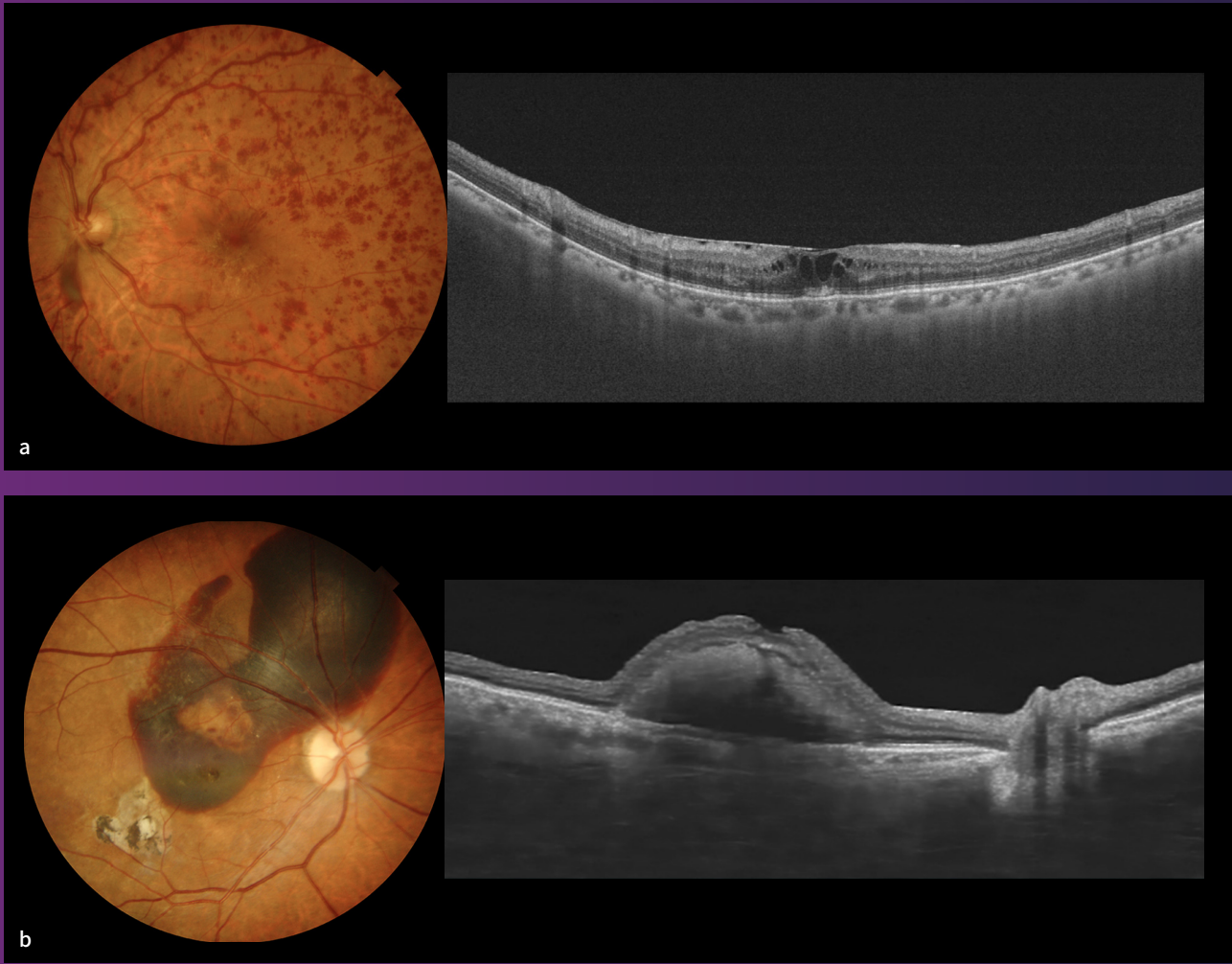

Courtesy: a : Dr. Takahiro Kawaji, Sato Eye & Internal Medicine Clinic,
b : Dr. Shozo Sonoda, Kagoshima Sonoda Oculoplastic Surgery Clinic

Some features in this brochure are only available with the IMAGENet7.

IMPORTANT In order to obtain the best results with this instrument, please be sure to review all user instructions prior to operation.
Not all products, services, or offers are available in all markets. Contact your local distributor for country-specific information and availability.

CE 0123

CLASS 1 LASER PRODUCT
(IEC60825-1:2014)
PRODUIT LASER DE CLASSE 1
(CE60825-1:2014)

TOPCON HEALTHCARE SOLUTIONS EMEA OY
Saaristonkatu 9, 90100 Oulu, FINLAND
Phone: +358-20-734-8190
E-mail: thsemea.sales@topcon.com
www.topconhealthcare.eu

TOPCON SCANDINAVIA
Neongatan 2, P.O.Box 25, 43151 Mölndal SWEDEN
Phone: +46-(0)31-7109200
Fax: +46-(0)31-7109249
E-mail: info.hcs.se@topcon.com
www.topconhealthcare.eu/sv_SE

TOPCON FRANCE MEDICAL
1 rue des Vergers, Parc Swen, Bâtiment 2, 69760 Limonest, FRANCE
Phone: +33-(0)4-37 58 19 40
Fax: +33-(0)4-72 23 86 60
E-mail: topconfrance@topcon.com
www.topconhealthcare.eu/fr_FR

TOPCON GREAT BRITAIN MEDICAL
Topcon House, Kennet Side, Bone Lane, Newbury, Berkshire RG14 5PX UNITED KINGDOM
Phone: +44-(0)1635-551120
Fax: +44-(0)1635-551170
E-mail: medical.tgbm@topcon.com
www.topconhealthcare.eu/en_UK

TOPCON FINLAND MEDICAL, TOPCON EUROPE MEDICAL B.V.: N SUOMEN SIVULIIKE
Martintalo complex, 3. floor Jaakonkatu 2, 01620 Vantaa FINLAND
Phone: +358-29-123-1260
E-mail: info.hcs.fi@topcon.com
www.topconhealthcare.eu/fi_FI

TOPCON EUROPE MEDICAL B.V.
Essebaan 69, 2908 LJ Capelle a/d IJssel THE NETHERLANDS
Phone: +31-(0)10-4585077
Fax: +31-(0)10-4585045
E-mail: medical@topcon.com
www.topconhealthcare.eu

TOPCON ESPAÑA
Oficina Principal en España Frederic Mompou, 4, 08960 Sant Just Desvern, Barcelona, SPAIN
Phone: +34-93-4734057
Fax: +34-93-4733932
E-mail: medica@topcon.com
www.topconhealthcare.eu/es_ES

TOPCON DEUTSCHLAND MEDICAL
Hanns-Martin-Schleyer-Strasse 41, D-47877 Willich, GERMANY
Phone: (+49)2154-885-0
Fax: (+49)2154-885-177
E-mail: info@topcon-medical.de
www.topconhealthcare.eu/de_DE

TOPCON IRELAND MEDICAL
Unit 292, Block G, Blanchardstown, Corporate Park 2 Ballycoolin Dublin 15, D15 DX58, IRELAND
Phone: +353-12233280
E-mail: medical.ie@topcon.com
www.topconhealthcare.eu/en_IE

TOPCON DANMARK MEDICAL
Praestemarksvej 25, 4000 Roskilde DANMARK
Phone: +45-46-327500
Fax: +45-46-327555
E-mail: info.todk@topcon.com
www.topconhealthcare.eu/dk_DK

TOPCON ITALY
Viale dell'Industria 60, 20037 Paderno Dugnano, (MI) ITALY
Phone: +39-02-9186671
E-mail: info_tit@topcon.com
www.topconhealthcare.eu/it_IT

TOPCON POLSKA SP. Z. O. O.
ul. Warszawska 23, 42-470 Siewierz POLAND
Phone: +48-(0)32-670-50-45
Fax: +48-(0)32-671-34-05
E-mail: info.tpl@topcon.com
www.topconhealthcare.eu/pl_PL

TOPCON NORWAY MEDICAL
St. Hansveien 10, 3614 Kongsberg, NORWAY
Phone: +47-32720072
E-mail: info.hcs.no@topcon.com
www.topconhealthcare.eu/nb_NO



TOPCON CORPORATION
75-1 Hasunuma-cho, Itabashi-ku, Tokyo 174-8580, JAPAN.
Phone: +81-(0)3-3558-2522/2502
Fax: +81-(0)3-3965-6898
www.topconhealthcare.jp

TOPCON Healthcare